

CUSTOMER'S NAME

Uniservice Co Ltd

ALPHA REFERENCE NO.

SP09020374

# SPECIFICATION

PART NO.	ALPHA MODEL NAME
1.	RV24AF-10E6-20K-XXX-10J9
	A1K-below A1M

MODEL NAME
MODEL NO.

APPROVAL

PREPARED BY	REVIEWED BY	APPROVED BY
 徐 98. 2. 26 鳳妮	 傅 98. 2. 26 任維	 王 2009. 2. 26 茂松



台灣艾華電子工業股份有限公司

桃園市中正路1221~1223號9樓

TAIWAN ALPHA ELECTRONIC CO., LTD.

9F, NO.-1221, Chung Cheng Rd., Taoyuan, Taiwan

TEL:886-3-3577799 FAX:886-3-3577700

E-mail:sales@taiwanalpha.com.tw

URL:http://www.taiwanalpha.com

SHAFT SHOWN IN FULL C.C.W. POSITION

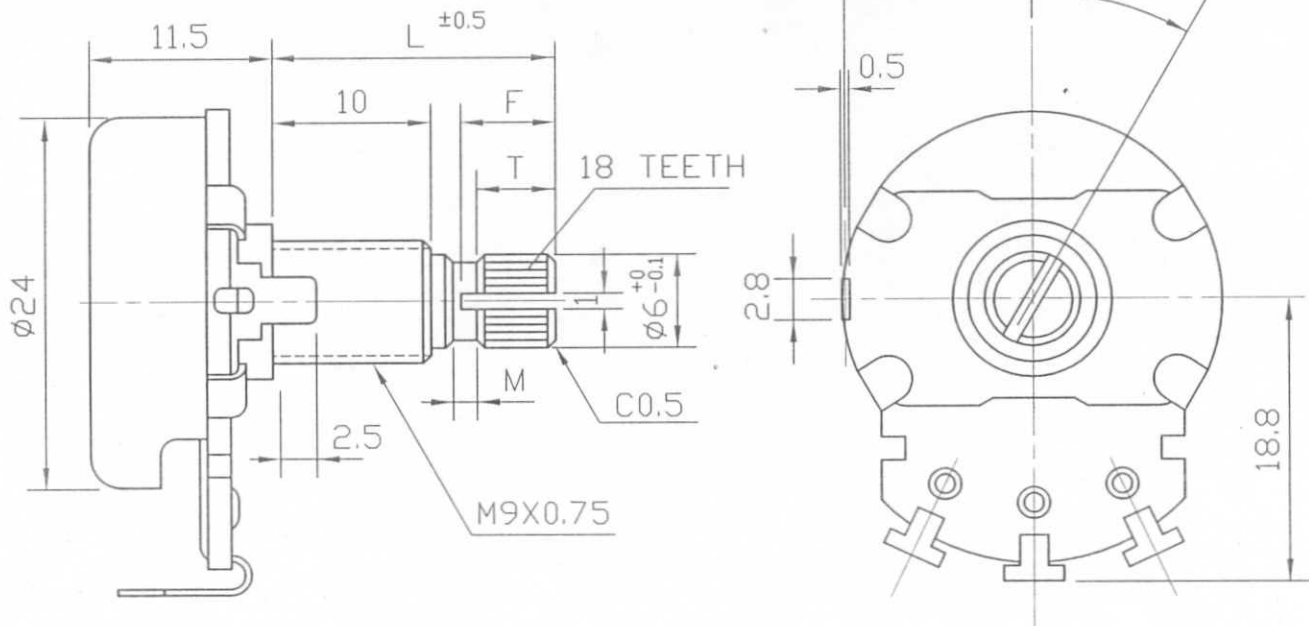

	L	F	T	M
	20	8	7	1.5

NUT

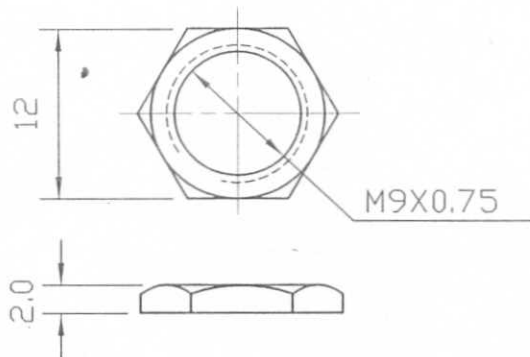

WASHER t=0.4

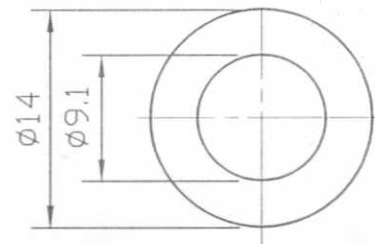

						-10J9
						RV24AF-10E6-(L)K-XXX-1

NO.	DATE	DESCRIPTION	MODEL NAME			
TOL. UNLESS OTHERWISE STATED	DIMENSION	SCALE	DRAWN BY	CHECKED BY	APPROVED BY	DRAWING NO.
less than 10 $\pm 0.3$	mm	2:1	傅 96.5.2 仕維	何 96.5.2 建志	楊 96.5.2 三鑫	
above 10 ~ 30 $\pm 0.5$						
above 30 ~ 100 $\pm 1.0$						
above $\pm 5$						

CUSTOMER'S NAME	Uniservice Co Ltd	NOTE	DATE FEB.26.2009.
CUSTOMER'S PART NAME			
CUSTOMER'S DRAWING NO.			

### 1. MECHANICAL SPECIFICATION

1. OUTSIDE DIMENSION	append fig.	
2. TOTAL ROTATION ANGLE	degree	300 ±5°
3. TOTAL TRAVEL STROKE	mm	±0.5
4. NUT WIRING STRENGTH	twisting moment	less than 9 kg.cm
5. SCREW TIGHTENING FORCE	torsional moment	less than kg.cm
6. ROTATION TORQUE	speed 60 deg/sec.	5~60 g.cm
7. SLIDING FORCE	speed 20mm/sec	g.cm
8. SHAFT LEVER STRENGTH	pulling pushing	more than kg
9. SHAFT LEVER WOBBLE	within mm (bending moment	g.cm)
10. SHAFT LEVER STOP STRENGTH	more than 6 kg.cm (static load) / 60 sec	
11. TERMINAL STRENGTH	more than 500 g.cm / 10 ± 1 sec	
	soldering heat 350±5°C/3sec. 200g.cm/10 ±1sec	
	resist change within ± 2%	
12. CLICK POSITION & TORQUE	g.cm	
13. SWITCH WORKING ANGLE (STROKE)	degree (mm)	
14. SWITCH WORKING TORQUE (FORCE)	g.cm	
15. SWITCH CIRCUIT		

### SHAFT

MATERIAL	ANGLE OF FLAT OR SLOT	DIMENSION			
	$\theta$	M	L	F	T
ALUMINUM	at				
			20		

MODEL NAME	DRAWING NO.
RV24AF-10E6-20K-A1K-10J9	

### 2. ELECTRICAL SPECIFICATION

1. OVERALL RESISTANCE & TOLERANCE	terminal 1-3	1K Ω± 20 %
2. TAP RESISTANCE & TOLERANCE	terminal 1-4	Ω± %
3. RATED WATTAGE	temp 0~50°C	0.25 W
4. MAXIMUM WORKING VOLTAGE		250 V
5. RESISTANCE TAPER MEASURING POINT & TOLERANCE		A 50 %point 10 ~ 25 %
6. RESIDUAL RESISTANCE	terminal 1/3 side	less than 20/20 Ω
7. TAP RESIDUAL RESISTANCE	terminal 4 side	less than Ω
8. SLIDE NOISE	speed 60° / 1 sec	less than 47 mV
9. INSULATION RESISTANCE	more than 100 MΩ(DC	500 V)
10. WITHSTAND VOLTAGE	AC 500 V	1 minute
11. TRACKING ERROR		
12. SWITCH CONTACT RESISTANCE	MΩ	less than mΩ
13. SWITCH RATING		

### 3. USABLE TEMPERATURE RANGE: from -10°C to 70°C

### 4. VR LIFE 15,000 ± TIMES

RESISTANCE CHANGE: within ± %

SLIDE NOISE : less than mV

### SW LIFE ± TIMES

CONTACT RESISTANCE: less than mΩ

REFERENCE NO.	REV
SP09020374	

# STANDARD RESISTANCE TAPER

## 15A TAPER (JIS A)

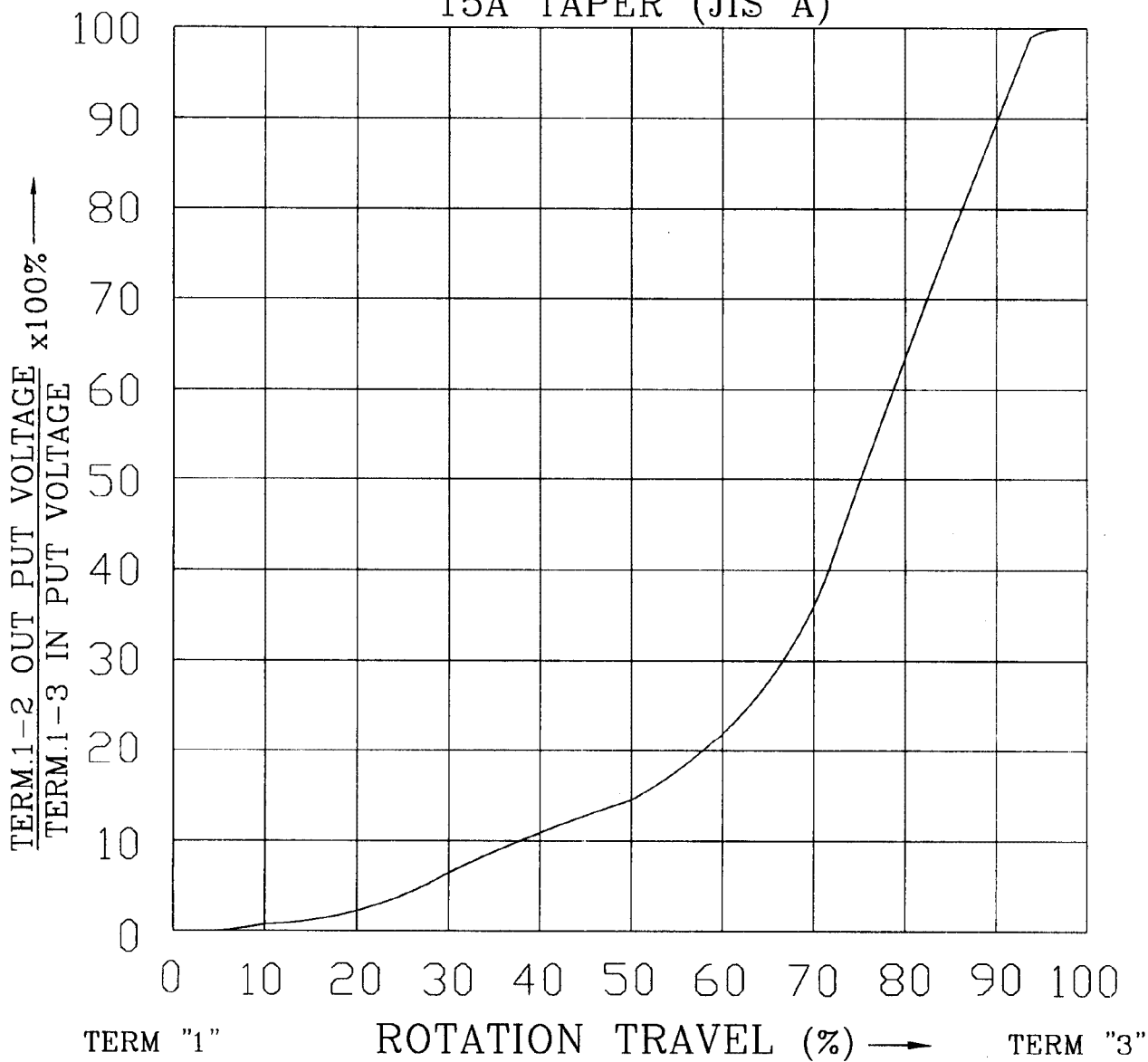

NO.	DATE	DESCRIPTION		MODEL NAME		
TOL. UNLESS OTHERWISE STATED	DIMENSION	SCALE	DRAWN BY	CHECKED BY	APPROVED BY	DRAWING NO.
less than 10 ±0.3	mm		何 90.8.21 建志	王 90.8.21 茂松	王 90.8.21 茂松	
above 10 ~ 30 ±0.5						
above 30 ~ 100 ±1.0						
above ±5°						

## 可變電阻無鉛焊錫共通規格書

### Common Specification of Lead-Free Soldering for Potentiometers

以下焊錫條件以可變電阻置於單層 1.6mm 厚度之印刷電路板上測試為基準。

The specification below is based on testing results of 1.6mm thickness single layer printed circuit board.

1. 手工焊錫條件：

**For Manual Soldering：**

1-1 操作溫度最高 350°C，操作時間 3 秒以內。

**To be performed within 3 seconds at 350°C or below.**

2. 自動或半自動機台焊錫條件：

**For Automated or Semi-Automated Soldering Equipments:**

2-1 使用發泡式且比重 0.82 以上的助焊劑，發泡高度以印刷電路板厚度一半為標準，且助焊劑不能流入可變電阻基板表面及印刷電路板表面。

**Flux of 0.82 specific gravity, applied by foam fluxer, shall be used. Foam head shall be limited to the height which is half thickness of printed circuit board to be soldered. No flux should be allowed to run up onto resistive element board of potentiometer and the surface of printed circuit board.**

2-2 預熱時間不超過兩分鐘，焊錫界面 (即印刷電路板底) 最高預熱溫度不超過 100°C。

**Regarding preheating, the entire flow duration should not exceed 2 minutes, and soldering surface temperature (undersurface of PCB) shall be settled within 100°C.**

2-3 焊錫過程機台設定溫度在 260°C 以下、4 秒以內。

**Solder Dipping is to be performed within 4 seconds at 260°C or below.**

3. 若可變電阻為帶有檔位，請將主軸或滑柄先調整至其中一個檔位或中心檔位上才可以進行焊錫作業。

**For potentiometer with centre detent or multiple detents, its shaft or lever should be settled in relevant detent position prior to soldering process.**

4. 手工焊錫、自動或半自動機台焊錫不得超過一回。

**Regardless of soldering facility and method, solder dipping or solder smearing must not be carried out more than 1 time.**

註：本項焊錫溫度條件不適用於回流焊接作業設備。

**Remarks : This specification is not recommended for and applicable in reflow soldering.**